

LINKS

FREE

Volume 20, Issue 20

"The Little Green Paper"

October 20, 2019

Community Links
Linking communities
Increasing knowledge
Expanding horizons
Offering opportunities.

Custom Printing:

Letterhead
Business Cards
Envelopes
Business Forms
Carbonless Forms
Note Pads
Office Supplies
Color Printing
Laminating

Vinyl

Signs, Banners, and License
Plates, Custom T-shirts, caps,
buttons and more!

**Printed and distributed bi-
monthly by persons with
disabilities.**

Editors:

Zia Partovi
Grace Peterson

Data Masters & Sales

Steven Burdick
Bobby Callison
Karen Deffenbaugh
Nikki Hamilton
Eric Peachey
Doug Stone
Breanna McDowell
Stephanie Baker
Heather Conn

Public Relations

Debbie Gray
Alanna Victor
Samantha Peterson

**Assembled at Midco Inc.
Little Green Shop &
Community Links in Chelsea**

Community Links
P.O. Box 85
Chelsea, OK. 74016
1100 Walnut in Chelsea
Phone 918-789-2862
Fax: 918-789-5296
communitylinks1999@
yahoo.com

Chelsea Outhouse Race



This year, Community Links of Chelsea participated in the Chelsea Outhouse Race. The Chelsea Outhouse Race is part of the Jamboree event that takes place the last Saturday of September every year.

Chelsea has been hosting Jamboree event for 84 years. The Outhouse race was introduced in the 80s. Later, this activity was removed from the event. However, due to the recent increase of interest in this race, it was brought back in 2015.

The Outhouse Race is a timed event: Outhouses must navigate a coned marked serpentine course to a marked parking spot. When in the parking spot, the pilot/driver must exit the outhouse to complete three obstacles.

Obstacle

OBSTACLE: Place the toilet paper onto the holder (something women think men are incapable of accomplishing).

Illustration



OBSTACLE: RING TOSS, Toss rings onto the neck of bottles, must achieve one ring on a bottle before proceeding.



OBSTACLE: NAVIGATE a ball down a tilting course before the final leg of the race.



Outhouse must be built to accommodate one driver and be pushed/pulled by 3 others.

TEAM:

A team shall consist of a maximum of four people of humanoid origin, including a driver (minimum age of 14 years). All must sign “hold harmless” agreement. Driver/Pilot must wear a helmet (bicycle, ATV, etc.) Community Link of Chelsea would like to thank James Elliott from Elliot's Auto Sales in Chelsea, OK for providing the Outhouse structure allowing us to participate in the race.

Community Links Team Members



Breanna McDowell



Doug WM Stone



Eric Peachey



Steven Burdick



Sammy Peterson



Allie Victor

Designing and Preparing The Outhouse For The Race

James Elliott painted the outhouse and the team decorated it. The team took over the whole process of preparing the Outhouse for race. The team came up with the design that included gold and silver stars, silver, dark blue, and white blue clouds, and white unicorn. The pictures included in the gallery shows the order of the design and decoration process as much as space in the article allows.



Nikki and Sammy Pushing Outhouse while Breanna Riding it



Allie cutting design on vinyl



Eric weeding stars off the vinyl



Breanna weeding clouds off the vinyl



Steve weeding out stars



Breanna thinking About Decorating Outhouse



Eric decorating outhouse with stars



Outhouse ready for race

2019 Outhouse Race

Team Responsibilities

Allie Pusher
 Steven Pusher
 Doug Pusher
 Breanna Rider

The race took about five minutes. The team had to push the outhouse for half a block to reach the obstacles.

The team had to stop to allow Breanna, the rider, to place toilet paper onto the holder stand (first obstacle) then toss ring to pass through the neck of bottles (second obstacle) and finally tilt the ball to drop it into the hole at the end of the tilting course (third obstacle). The team had to push the outhouse for another half

a mile to reach the finishing line.

Even though it was hot but the team really enjoyed the process from the designing, preparation, decorating, to participating in the race. They are looking forward to the race next year.

Breanna especially enjoyed decorating and the games. She felt weared riding on the potty.

Doug said even though it was hard to push the card I enjoyed the race. He wants to be the rider next year.

Steve enjoyed everything very much. He loved decorating the outhouse. He enjoyed the race itself. He wrote his name on the wall inside. He believes he gained good experience. He likes Community Links to participate in the race in the future.

Eric enjoyed decorating the outhouse as much as he enjoyed weeding vinyl for the stars. He also likes Community Links to participate in the race in the future.

Sammy liked decorating and watching the team struggling pushing the outhouse.

Allie's favorite part was working with the team.

Debbie believes it was great teamwork. The process went smoothly. Everybody had great contributions. She is very proud of the team.



Breanna placing toilet paper onto the holder stand



Breanna is tossing ring to go around the neck of one of the bottle neck



Breanna tilting the course trying to get the ball into the hole at the end of the tilting course



Stephanie and Breanna

By Nikki Hamilton and Zia Partovi



Team standing next to the outhouse



Race started



Breanna getting ready for race



Race continues

(918) 785 - 2520

•Cowhide Corner•

101 N Mayes
Adair Oklahoma 74330

Larry & Patsy Eby
Owner

CHELSEA

FAMILY PHARMACY

THE PHARMACY THAT CARES

600 Walnut * Chelsea
918-789-2241

Email: chelseafp@sbcglobal.net
www.chelseafamilypharmacy.com
Joe Forcum, D. PH
Wendy Forcum

Rogers County Fair Contest



Two contestants, Grace Taylor and Breanna McDowell participated in the Rogers County Fair contest at the Claremore Expo Center.



Grace Taylor



Breanna McDowell

Grace's Accomplishments

- Division 112—Senior Crafts, Class 15 contest she won 2nd. Place for painted ceramic hen.
- Division 112—Senior Crafts, Class 14 contest she won 3rd. Place for glazed ceramic horse head mug.
- Division 110—Adult Crafts, Class 4 contest she won 4th. Place for painted ceramic white tiger.



Breanna's Accomplishments

- Division 110—Adult Crafts, Class 4 contest she won 2nd. Place for painted ceramic blue squirrel.
- Division 104—Adult Art, Class 23 contest she won 4th. Place for mixed media painting.



By Doug WM Stones and Zia Partovi

To share your story with us contact:
Zia Partovi at 918-244-0457 or 918-789-2862 or
email him at links@links.community-options.net

Community Options Employee Of The Quarter

Teresa Heard has been chosen as Community Options Inc Employee of the Quarter. Teresa has excellent attendance. When working, she does any and all activities that require attention. She interacts with the individuals served, works with them on their outcomes and accompanies them on outings when needed. She strives to keep things lighthearted and pleasurable.

Teresa readily accepts change and will endeavor to implement new ideas and suggestions.

Teresa works hard at making the house feel like a home. She assists the ladies in decorating for every holiday making the home inviting and comfortable.

Since the move to the new house, during nighttime hours when the ladies are sleeping, Teresa busies herself by unpacking their belongings and putting them away.

For these reasons we have selected Teresa as Employee of the Quarter.



"I am glad a friend told me about..."

**GRAND
PROSTHETICS**
& Orthotics

Lightweight

ARTIFICIAL LIMBS & BRACES

FREE CONSULTATIONS

(918) 786 4626

www.GrandPro.com

5 East 14th St Grove Ok 74344

**Chelsea
Tag Office**

336 W. 6th * Chelsea, OK.

789-2332

Open Monday thru Friday
9am to 12pm 1pm to 5pm
and 9am to 12 pm Saturday
Marie White Agent

A Tattoo Named Lost

Got on the plane in Minneapolis for the two hour and nine minute flight to NY. Spent the first nine minutes of it talking to the young curly-brown-haired passenger with long sideburns. In the first three minutes of talking to him I noticed on the back of his hand a ball-point-pen tattoo. One word.

"Lost".

And for some reason that touched me. In the same inexplicable way that "Help Wanted" signs in store windows do sometimes. That people would be so honest, so open about their vulnerability.

I wonder what he is going through.

This fellow passenger with his friendly manner who freelances for the magazine "Popular Photography" and moved back to his hometown in Lawrence, Kansas from NY- because even though there's a lot you can do in NY there's a lot that you can't do there when you're broke. And now he's learning how to do video editing and trying to teach himself graphic design. He wishes he'd taken classes in that in college instead of Literature- he thinks it would have been more- Useful. So I talk a little bit about Literature and how it can shape you and your perspective in sometimes unsuspected-but positive ways- how it can grow you towards understanding the human experience, how it can make you less judgemental and in some odd but real way- more-compassionate. And he resonates unexpectedly with some of this.

We talk then about documentary filmmaking and the beauty of working creatively with reality. I tell him about a documentary I made and pull out a copy from my hand luggage to show him. He looks at a moment or two in silence and then asks hesitantly- Can I buy this from you?

No. I say.

But you can keep it. Even though I don't usually give them away. Something in me really wants to share this story with this random stranger from Kansas and it seems suddenly like an improbable miracle that I have this opportunity to do it. :-) He is surprised and touched by the gesture.

Before landing I wrote a short note to passenger 38 D. It was the "bill" for the documentary: three Smile Cards and instructions to use them creatively by way of payment. I decided to hand it to him at the Baggage Claim right before leaving. As the flight descended though I had to ask one question: "What is that about,"

I ask, pointing to the back of his hand and trying to sound as genuinely caring-as-opposed-to-curious as I feel.

"Oh that. That's the title of a series my girlfriend wanted me to pick up before I caught the flight. It's about a group of people marooned on an island after a plane crash. I just wrote it on my hand to remind me to pick it up."

Oh.

At the baggage claim I watch Passenger 38 D help elderly passengers get their bags off the conveyer belt. He seems just the kind of person who would have fun with three smile cards. :-) Before he leaves I hand him his "bill" not to be opened until he's left the airport. He is surprised and shoots me a quizzical smile before putting it in his pocket. "By the way my name is Mark," he says.

We shake hands and he leaves.

And I am still smiling.

Source: Kind Spring

By: Singlestep

Website: <https://www.kindspring.org>

DATA MASTER: Doug WM Stone

To share your story with us contact:
Zia Partovi at 918-244-0457 or 918-789-2862 or
email him at links@links.community-options.net



Beyond our Boundaries



There is a newcomer Syrian family in my community who have lost children and relatives during the war. I've assisted them in many ways and we are now close friends despite the fact that they are Muslims and I am Jewish.

They've assisted me in return and we are now like family in kindness and friendship. Indeed, in our small Canadian city we took in many Syrian refugees. Many of us also signed up to learn Arabic.

Although we are all very different, we have respected and honored those differences through the Canadian philosophy of the individual being important, but within the group. Our group has expanded and enriched all of our lives.

Source: Kind Spring

By: Aaylyn

Website: <https://kindspring.org>

DATA MASTER: Breanna McDowell



www.sbtmiami.com
918-542-6661

**BANK
ANYWHERE
& ANYTIME
WITH OUR
MOBILE APP**



FOUR CONVENIENT LOCATIONS TO SERVE YOU
MIAMI | NORTH MIAMI | AFTON | COMMERCE

MEMBER FDIC

Proudly Accepting: **SOONERCARE & MEDICAID**



HAPPY TOOTH
Jonah R.B. Vandiver, DDS & Associates

TOOTH-COLOR FILLINGS
RELAXING GAS • CLEANINGS
EXTRACTIONS • SEALANTS
X-RAY/EXAMS • EMERGENCIES
NEW Patients Welcome!
We love working with both children & adults.



HappyToothOK.com

900 E. Will Rogers Blvd, Suite A • CLAREMORE **341.6900** 7104 S. Sheridan Suite B • TULSA **492.8793**



DpTABLETALKERS

Home of The Mini Billboard

Let's market your business
with mini billboards
on restaurant table tops.



*Your color ad will be seen thousands of times
over a two year period.*

Check out the website: www.dptabletakers.com
email: dptabletakers@gmail.com Call or Text: 918-640-4286

We will be glad to help you with your marketing needs.

Claremore Nursing Home - Employee of the Month



Employee Of The Month... Samantha Walker voted Employee of the Month by the residents. She was born in San Antonio, TX on November 15th. She has been a CNA here for 10 years. She has two daughters but no longer married. Her hobbies are fishing and swimming but really likes doing anything with her girls. Not many people knows she likes to paint and draw. We all know she loves to mow but only with a push mower. "I love the fact that Claremore Nursing Home feels like home and we work as a team."

If you would like to join, "Samantha Walker" as a Certified Nurse Aide, please apply in person. Now taking applications for Certified Nurse Aides both days and nights. Must pass a background check. New pay scale for CNA's.

"They may forget your name, but they will never forget how you made them feel."

Maya Angelou

Claremore Nursing Home
920 E. 16th St.
Claremore, Ok. 74017
918-341-1717

To share your story with us contact:
Zia Partovi at 918-244-0457 or 918-789-2862 or
email him at links@links.community-options.net



721 W. 6th Claremore 341-0933
Open: M-F 8-6 & Sat 8-5



Community Options, Inc.
website is operational

Pay a visit to our website to learn about what we are doing and how you can help others by getting involved.

If you are seeking for employment you can apply for your desired position with us online.

our website can be accessed at:
<https://community-options.net>

Everything Is Waiting For You



Your great mistake is to act the drama as if you were alone. As if life were a progressive and cunning crime with no witness to the tiny hidden transgressions. To feel abandoned is to deny the intimacy of your surroundings. Surely, even you, at times, have felt the grand array; the swelling presence, and the chorus, crowding out your solo voice. You must note the way the soap dish enables you, or the window latch grants you freedom. Alertness is the hidden discipline of familiarity. The stairs are your mentor of things to come, the doors have always been there to frighten you and invite you, and the tiny speaker in the phone is your dream-ladder to divinity. Put down the weight of your aloneness and ease into the conversation. The kettle is singing even as it pours you a drink, the cooking pots have left their arrogant aloofness and seen the good in you at last. All the birds and creatures of the world are unutterably themselves. Everything is waiting for you.

Source: Awakin (Waking up to Wisdom In Stillness and Community)

By: David Whyte

Website: <http://www.awakin.org>

DATA MASTER: Eric Peachey



Bruce Parks 7454 South Hwy 28
918-789-2694 Chelsea, Oklahoma 74016
918-637-2106 Cell Bruce@ParksCustomCabinets.com
918-283-7030 Fax www.ParksCustomCabinets.com

Zen Of Archery

In the 1920s, a German professor named Eugen Herrigel moved to Japan and began training in the martial art of archery, with a legendary archer named Awa Kenzo. Kenzo was convinced that beginners should master the fundamentals of archery before attempting to shoot at a real target, and he took this method to the extreme. For the first four years of his training, Herrigel was only allowed to shoot at a roll of straw just seven feet away.



When Herrigel complained of the incredibly slow pace, his teacher replied “The way to the goal is not to be measured! Of what importance are weeks, months, years?”

When he was finally permitted to shoot at more distant targets, Herrigel’s performance was dismal. The arrows flew off course and he became more discouraged with each wayward shot. During a particularly humbling session, Herrigel stated that his problem must be poor aim.

Kenzo, however, looked at his student and replied that it was not whether one aimed, but how one approached the task that determined the outcome. Frustrated with this reply, Herrigel blurted out, “Then you ought to be able to hit it blindfolded.”

That night, Kenzo took Herrigel to the practice hall, with the target hidden in the dark. Settling into his firing stance, Kenzo drew the bow string tight, and released the first arrow into the darkness. Bullseye. He drew another one. Bullseye again.

Complete awareness of body and mind in relation to the goal is known as 'zanshin'. Literally translated, zanshin means “the mind with no remainder.” In other words, the mind completely focused on action.

We live in a world obsessed with results. Like Herrigel, we have a tendency to put so much emphasis on whether or not the arrow hits the target. If, however, we put that intensity and focus and sincerity into the process -- where we place our feet, how we hold the bow, how we breathe during the release of the arrow -- then hitting the bullseye is simply a side effect.

Source: Awakin.org (Waking up to Wisdom In Stillness and Community)

By: James Clear

Website: <https://www.awakin.org>

DATA MASTER: Steven Burdick

It Could Be Worse

I imagine that the very last person to survive the end of the world as we now know it, will at some point turn around and say to no one there at all—“Damn! But I guess it could be worse!” It’s a pretty darn universal coping strategy I find. And an effective one. It demands that we step back from our current circumstances and get a larger perspective. And it sort of insists that we muster some kind of gratitude for whatever we do have, slapping us into an “attitude of gratitude.” In my work as a cancer chaplain, at the Simms/Mann-UCLA Center for Integrative Oncology, I would say that upwards of 90% of the folks I’ve seen over the years would make some form of this claim and take comfort in it— “It could be worse.” “I’m just so glad they caught the cancer early.” “I’m just glad it hasn’t metastasized.” “At least I don’t have to have radiation.” “At least I’m 55 years old and have had a life... look at these kids who get cancer.” “I’m glad it’s me and not my children.” Like I say, it’s an effective tool.

I had a breast cancer patient, Margie. She’s an energetic, feisty gal in her 70’s with this bubbly spirit and a dry, slightly devilish sense of humor... someone my mom would call “a kick in the pants.” Margie’s also a bit of a busybody, flitting around the clinic with her IV stand in tow, chatting up the other patients. She’s designated herself as my agent. “Michael, see that woman in the third chair over there? I think she really needs to talk to you.” One day Margie opened with, “Michael, I’m a terrible person. I am! I USE all these people. Isn’t that awful? I do. I look at all of them and what they’re going through and think, ‘I haven’t got it so bad,’ and it makes me grateful.” Her tongue was firmly in her cheek in a way, but she was making a deadly serious point. There’s a real truth in what she says.

It speaks to that part of us that is so aggravated to find ourselves the last person in an impossibly long line at the bank, supermarket or post office. And as soon as someone steps behind us in line, we feel better! We’re no closer to getting our business done, but, “at least I’m not where YOU are!” Every time I turn around and look behind me, I feel better. Like it’s some kind of Spiritual Ponzi Scheme! The thing about Ponzi schemes though is that someone has to lose. Someone has to be left holding the empty bag. And where does that leave us in our pursuit of a life lived with compassion at its core?

The other thing about the Spiritual Ponzi Scheme is that there is a prerequisite to buying in. And that is a firm belief in a hierarchy of suffering. A belief that, “I know who’s suffering the most here,” and so I will dole out my compassion accordingly. Here’s another

place that can trip us up in our attempt to walk a compassionate path. Because while I might be filled with gratitude that I’m no longer the last in line, or at the bottom of the pyramid, I’ve also just created a barrier to experiencing an authentic compassion for others and for myself. I’m way too busy judging the line-up in the Suffering Sweepstakes and figuring out where I fit in.

And I do want to say a few words about compassion itself. Compassion, the word, at its Latin root, “com-pati” literally means WITH suffering. Not fix suffering, correct suffering, relieve suffering, judge suffering, or feel bad about the suffering... but to be with... to walk beside the one who is suffering. Not an easy thing. Virtually every religious tradition in the world places a very high value on the virtue of compassion. Why is it that compassion for others is seen as a virtue and yet compassion for self is somehow seen as a vice or moral weakness? We tend to harshly judge compassion for self and characterize it as “self pity.” Oh we don’t want that! (And I think we know the difference between one who may seem very attached or even addicted to a sense victimhood and uses that as a pathway to navigate life, and one who can honor the truth of, “Hey, I’m going through a rough time here!”.) I would ask, can we truly walk beside others in their suffering in an authentic way if we don’t know how to carry and walk beside our own?

I had been referred to Valerie by one of the infusion nurses on her first day of chemo. She’s in her mid 30’s, a working mom with a 4-year-old daughter, newly diagnosed with breast cancer. Valerie’s deepest grief, worse than the diagnosis, was hearing the news that she won’t be able to give birth to a second child—she and her husband had been trying to get pregnant again when she was diagnosed. She also grew weary of trying to keep spiritual scorecards... “I know, I should be grateful! I do have one healthy daughter and a wonderful husband and family, and I have good insurance— Look at all the people starving in Africa!” (Why is it that Africa always seems to be in the default position at the bottom of the Spiritual Ponzi Scheme Pyramid?) Valerie was even less patient as others tried to keep that scorecard for her. “Valerie, at least you have one child! Think how many people can’t have even one!” No one in her world was simply allowing her to have her grief and disappointment-- just be a witness to her loss. With Compassion.

There is a price we pay, individually and collectively, to live out our own life’s journey without sharing the pain of that journey as much as we would want to share our joys and pleasures. For one thing, we deny life around us from really knowing us, what it’s like to

be us, keeping true intimacy at arm's length. If only the last person in line at the post office, or the cancer patient, or the starving person in Africa is entitled to complain or to our compassion, what on earth would the rest us talk about? Like Jane Wagner says, "I personally think we developed language because of our deep inner need to complain." Of course I'm not advocating that we now all complain 24/7... all complaining, all the time (as if some of us don't do that already!) But I am inviting us to reflect upon our capacity to honor each other's journey, each other's reality, including our own without judgment, or the need to place each circumstance on our Hierarchy of Suffering scale. And can we honor each reality in all its layers of complexity and contradiction?

A number of years ago I had a patient Lorne. Lorne was from Bakersfield, in and out of the hospital a dozen times over the course of a year. His wife Mary by his side each step of the way. These are older working class people away from home. There were several times Lorne came close to death's door, and I was summoned to his bedside. Then he would bounce back. But as it became clear Lorne hadn't much time left, Mary confided in me: "Michael I love my husband and I'm grateful to have him for another day, but every day he lingers in the hospital costs me more than \$100 for the motel, and I know I'm not supposed to care about that, but I have to. How am I going to pay for it? Does that make me a bad person to be worried about that?"

Like Mary, we all live in multiple realities at once. The image that comes to my mind is going into a Best Buy or some such place and you see this endless wall of TV screens for sale—each one tuned to a different show. I think our individual and communal lives are like that wall of TV screens. Each TV show has its reality, its context, its goals... whether it's a game show, a situation comedy, a drama, the news, a sports program or a National Geographic special. None is more legitimate or innately valid or valuable than another—they simply are the reality that they are, and yet no one show captures the entire reality of our lives in all their complexity. Perhaps the entire wall is the best image of that.

Yet through our participation in the Spiritual Ponzi Scheme and the Hierarchy of Suffering, we think we know which is most legitimate, most important, most worthy of our time, energy and compassion. The very part of us that might silently chastise Mary, if only for a moment, for worrying about money at a time like this. That is until we're slapped awake into another reality and find ourselves in another show!

I have a colleague Amanda, with whom I've worked on a few workshops. When I first worked with her, she had shared with me this revelation she had had with respect to her marriage of 30-some years. "Michael, we have a great marriage, but I have to say I've been so irritated for over 30 years about our carport. My husband has had it packed to the rafters with crap. I was so sick of looking at it, but always trying to tell myself, 'It just isn't important. Let it go.' So he surprised and had the carport covered with siding and turned into a garage, so I don't have to look at all the crap. You cannot believe the difference it has made in our marriage! It's just amazing!" Six months later, I worked with Amanda on another conference. I found out her home and garage had been swallowed up by a brush fire. Gone. Where's the irritant now? Different TV show.

I spoke earlier about Africa, at the bottom of the pyramid. A number of years ago, my husband Scott and I made a trip to South Africa and Zambia. We went to a small village in Zambia of about 3000 people situated on a gentle hillside. Everyone lived in mud huts, no electricity or running water. There was a pump at the bottom of the hill, to which all the villagers trudged many times a day with buckets in hand. And yet there were geraniums planted in bleach bottles cut in half to frame the doorways of the huts. There were dogs and cats nurtured as pets. In the midst of what we would consider impoverishment, there was a generosity of spirit that could create room for extraneous beauty and the love of animals. And a humbling hospitality for this wealthy American who was so busy taking video that he didn't notice the bucket of water at his feet before he kicked it over. "Oh please, can I go down the hill and pump some more water for you." Our host wouldn't hear of it. He only smiled and laughed. "You are our guest!" I certainly don't mean to assert that there's no suffering there, so we don't need to concern ourselves. As if we're off the moral hook for our comparative wealth and consumption of the earth's resources.

Could it be, that in some ways, the "Zambian Village" show may be simpler or more comprehensible-- offer more clarity perhaps than "The-Carport-Is-Driving-Me-Crazy" show? Is it possible that in some ways the suffering may be less? Priorities and action plans must become crystal clear when the goal of the show is: get through the day without dying. I will say that when I left that village, I left not with such gratitude for what I have, but longing for some of what they have. For what? Acceptance of what is? Unencumbered hospitality? Freely given joy and smiles? A clear sense of place in one's community?

Perhaps it's best not to judge the TV show. The Buddhists offer the concept of "beginner's mind"—to come to each situation, each encounter, empty... "I know

nothing.” As a pathway to being more fully present, available to discovery. Perhaps it’s best to come to each TV show we watch, and each one in which we find ourselves, with beginner’s mind. Particularly if I’m committed to an inclusive kind of spirituality that holds compassion at its center. What if suffering is suffering, the flavor of that suffering just depends on the show?

I would suggest that when a 2-year-old drops her ice cream cone and cries over the loss, that that suffering is as real as for us receiving a cancer diagnosis. We can admonish her with judgement and say, “Don’t cry! It’s just an ice cream. I’ll get you another one.” But to her, “I wanted THAT ice cream! And I feel ashamed and foolish for being reckless with something so precious. And I don’t have the words for all that so I’ll just wail.”

A few years back, before Scott retired, he was traveling a lot for his work. In order to save money on taxis and airport parking, I would make many runs to and from LAX. I need to tell you that Scott loves to wrap presents—if he could’ve made a decent living wrapping presents he would have done that. When we go on our travels and I look for some artifact or souvenir to take home, Scott looks for wrapping paper. It is truly an event to open a gift from Scott. It’s part of how he expresses his creativity and love.

So late one Sunday night in December I headed down to LAX to pick up Scott—a flight from Chicago that was already many hours late. Tomorrow, Monday was to be the holiday party at work at which he would present the gifts he’d carefully chosen for his staff. When in Chicago, he went to one of his favorite stores to buy some exquisite wrapping paper for the gifts. He was sitting for hours on end at O’Hare, and when his flight was finally called, he got up to discover that the shopping bag full of wrapping paper that he’d set down next to him was gone. Stolen. Frantic, he asked the woman sitting across from him if she’d seen anyone take the bag. “Well yes I did, but I didn’t think a MAN would be travelling with wrapping paper!” she sniffed. So to compound the loss, he got a sexist/homophobic slur in the bargain.

So I picked him up about midnight. Needless to say he was a wreck. (He had one good nerve left, and I had two.) Out of a loving (but not truly compassionate) desire to fix the situation, I suggested, “Well Honey, maybe we could go to the 24 hour Rite-Aid and find some paper.” Oh the look he gave me! To suggest such a thing would be like... “Well, the Queen of England is coming to dinner, but the oven broke today, so why don’t you go make a run to McDonalds and pick some-

thing up?” It just would NOT do. And there is a part of me that wants to play the chaplain card, without remotely being a chaplain. “SCOTT! It’s wrapping paper! It’s not cancer! Can I tell you about the case I had on Friday? Let’s get a grip!”

But the truth is, he was suffering. His suffering was very real. And he was experiencing genuine loss. The once-a-year opportunity for him to show his staff in his own inimitably creative way, how much he appreciated them, was stolen from him. And I could judge it... any of us could, easily. Or in that moment we could choose to come sit beside the suffering. Not judge the TV show. You can’t compare the cancer show to the Scott show in that moment. We do have a choice to make.

So can I be fully present in my own TV show of this moment, whatever it is... maybe it’s the “Damn-I-Spilled-Bleach-On-My-Favorite-Pants” show or maybe it’s the “My-Mom-Has-Lung-Cancer” show? But without judgement? Without the need to compare for validity or worthiness of compassion? All the while still nurturing gratitude for what I have and knowing... conscious that there are other shows going on at the same time... And I’m in some of them-- simultaneously... like Mary: lost in the “My-Husband’s-Dying” show, and in the “How-Will-I-Pay-My-VISA-Bill” show. And in some shows, I don’t make an appearance-- ever... foreign territory. Maybe part of my spiritual journey is to watch as many shows as possible with beginner’s mind. Maybe then I can inch closer to truer kind of compassion, a more inclusive kind of spirituality.

And if not... well, it could be worse

Michael Eselun, BCC, a Board Certified Chaplain, serves as the chaplain for the Simms/Mann-UCLA Center for Integrative Oncology. Widely published in journals, Michael also has two TED talks available via YouTube. www.MichaelEselun.com

Source: Daily Good

By: Michael Eselun

Website: <http://dailygood.org>

DATA MASTERS:
Breanna McDowell
Steven Burdick

Small Acts of Trix-Mix

Some deeds are big some are small, but the point is for us to think of other people.



I want to share the lovely feeling of joy on being around a bunch of 4 year olds for whom I was a complete stranger yet felt so bonded by my presence and connection.

Early this week, I offered to do some story time reading at a local preschool. The kids and teachers were very excited about it. It was wonderful to be around these incredible kids who all picked their favorite storybooks for me to read. Due to time constraint, I could only read few books but promised the other kids to read them their favorite story the next time. I already made 2 trips to the school to keep my promise and looking forward to more!

I was thinking of ways to show my appreciation to the teachers and staff of an Elementary school that my daughter goes to. I made a small card, tied a bunch of fresh flowers and added a bag of home made cookies. I dropped in a Smile card along with the rest of the stuff and asked my daughter to anonymously drop it off at the school office. She immediately asked me if she could do the same for the school Janitor, Mr. Perez to make his day and feel him appreciated (we plan on doing that next Monday since Friday is their school day off).

To keep myself going, this afternoon I decided to show my appreciation for the mailman. I bought a bag of trix-mix and after putting it in a bag with a hand made card and a "SMILE Card", I left it at the mailbox (community mailbox to keep it anonymous!)

Source: Kind Spring

By: Anita

Website: <https://www.kindspring.org>

DATA MASTER: Karen Deffenbaugh

John's Body Shop

Collision Repair Professionals

Excellent Color Matching

Unibody And Frame Repair

Glass Replacement

Insurance Claims Welcome

johnsbodysshop85@att.net

918 789-3184

We Repair It Right The First Time



Chelsea

Johnny Parks

DUTCH PANTRY

BUFFET & BAKE SHOP

Craft Items Available

HOURS: Thurs. - Sat. - 8:00am - 9:00pm

Mon., Tues. & Wed. - Until 8:00pm

918-476-6441

VERNON DETWEILER

Main & Railroad
Chouteau, Ok 74337



PIZZA CORRAL

Daily Lunch Buffet

Dine In * Take Out * Drive Thru *

Pizza * Sandwiches * Salad Bar * Pasta

476-4507

HWY 69 South, Chouteau, OK

To share your story with us contact:
Zia Partovi at 918-244-0457 or 918-789-2862 or
email him at links@links.community-options.net

My Neighbor's Corn



There was once a farmer who grew excellent quality corn. Every year he won the award for the best corn. One year a newspaper reporter interviewed him and learned something interesting about how he grew it. The reporter discovered that the farmer shared his seeds with his neighbors.

“How can you afford to share your best seed corn with your neighbors when they are entering in competition with yours each year?” the reporter asked.

“Why sir,” said the farmer, “Don’t you know? The wind picks up pollen from the ripening corn and swirls it from field to field. If my neighbors grow inferior corn, cross-pollination will steadily degrade the quality of my corn. If I am to grow good corn, I must help my neighbors grow good corn.”

So it is with our lives. Those who want to live meaningfully and well must help enrich the lives of others, for the value of a life is measured by the lives it touches. The quality of response and joy depends on the quality of thoughts and love we share and spread.

And those who choose to be joyful must help others find happiness, for the welfare of each is bound up with the welfare of all.

Naren Kini is an entrepreneur in the Silicon Valley, Heartfulness meditator for decades, and loves music, writing and drawing. The artwork above is his own sketch.

Source: Awakin Organization - Waking up to Wisdom in Stillness and Community

By: Naren Kini

Website: <http://www.awakin.org>

DATA MASTER: Eric Peachey

The Way of the Water



We have glamorized the way of the warrior for millennia. We have identified it as the supreme test and example of courage, strength, duty, generosity, and manhood. If I turn from the way of the warrior, where am I to seek those qualities? What way have I to go?

Lao Tzu says: the way of water.

The weakest, most yielding thing in the world, as he calls it, water chooses the lowest path, not the high road. It gives way to anything harder than itself, offers no resistance, flows around obstacles, accepts whatever comes to it, lets itself be used and divided and defiled, yet continues to be itself and to go always in the direction it must go. The tides of the oceans obey the Moon while the great currents of the open sea keep on their ways beneath. Water deeply at rest is yet always in motion; the stillest lake is constantly, invisibly transformed into vapor, rising in the air. A river can be dammed and diverted, yet its water is incompressible: it will not go where there is not room for it. A river can be so drained for human uses that it never reaches the sea, yet in all those bypaths and usages its water remains itself and pursues its course, flowing down and on, above ground or underground, breathing itself out into the air in evaporation, rising in mist, fog, cloud, returning to earth as rain, refilling the sea.

Water doesn’t have only one way. It has infinite ways, it takes whatever way it can, it is utterly opportunistic, and all life on Earth depends on this passive, yielding, uncertain, adaptable, changeable element.

The flow of a river is a model for me of courage that can keep me going — carry me through the bad places, the bad times. A courage that is compliant by choice and uses force only when compelled, always seeking the best way, the easiest way, but if not finding any easy way still, always, going on.

excerpted from the post The Election Lao Tzu and A Cup of Water.

Source: Awakin Organization – Waking up to Wisdom In Stillness and Community

By: Ursula LeGuin

15 **Website:** <http://awakin.org>

DATA MASTER: Eric Peachey

The Seven Wonders



Anna was a 9-year-old girl from the small village. She finished attending elementary school till 4th grade at her village. For the 5th grade onwards, she will have to get an admission in a school at a city nearby. She got very happy knowing that she was accepted in a very reputed school in a city. Today was the first day of her school and she was waiting for her school bus. Once the bus came, she got in it quickly. She was very excited.

Once the bus reached to her school, all students started going to their classes. Anna also made it to her classroom after asking fellow students for direction. Upon seeing her simple clothing and knowing she is from a small village, other students started making fun of her. The teacher soon arrived and she asked everyone to keep quiet. She introduced Anna to the class and told that she will be studying with them only from today.

Then the teacher told the students to be ready for the surprise test now! She told everyone to write down the 7 wonders of the world. Everyone started writing the answer quickly. Anna started to write the answer slowly.

When everyone except Anna had submitted their answer paper, the teacher came and asked Anna, "What happened Dear? Don't worry, Just write what you know as other students have learned about it just a couple of days back".

Anna replied, "I was thinking that there are so many things, which 7 I can pick to write!" And, then she handed her answer paper to the teacher. The teacher started reading everyone's answers and the majority had answered them correctly such as The Great Wall

of China, Colosseum, Stonehedge, Great Pyramid of Giza, Leaning Tower of Pisa, Tajmahal, Hanging Gardens of Babylon etc.

The teacher was happy as students had remembered what she had taught them. At last the teacher picked up Anna's answer paper and started reading.

"The 7 Wonders are – To be able to See, To be able to Hear, To be able to Feel, To Laugh, To Think, To be Kind, To Love!"

The teacher stood stunned and the whole class was speechless. Today, a girl from the small village reminded them about the precious gifts that god has given us, which are truly a wonder.

Moral: Value what you have, use what you have, trust what you have. You don't always have to look away to find an inspiration. God has given you all the strength to reach your goals.

Source: Moral Stories
Website: <https://moralstories.org>

DATTA MASTER: Karen Deffenbaugh

WINCHESTER ADVISORY CENTER
FULL LINE BROWNING DEALER

BILL'S SPORTING GOODS
*Archery • Black Powder • Ammo
Guns • Reloading*

1016 S. LYNN RIGGS
CLAREMORE, OK 74017

MON - SAT 9-6
918-341-5388
FAX 918-341-8449

www.billssportinggoodsok.com



Community Options, Inc.
website is operational

Pay a visit to our website to learn about what we are doing and how you can help others by getting involved.

If you are seeking for employment you can apply for your desired position with us online.

our website can be accessed at:
<https://community-options.net>

Eastwood Manor, LLC

6th & Highway 69, P.O. Box 100

Commerce, OK 74339

"Where Caring Makes A Difference."

Pam Cozort, Administrator

(918) 675-4455

Fax (918) 675-5472

www.eastwoodmanorllc.com

Terry Young Truck • Auto • Tractor • Lawn Mower • ATV
Owner

Monday - Friday:

8 am - 5 pm

Saturday:

8 am - 12 pm

(918) 256-2127

348 N. 6th • Vinita, OK

(corner of 6th & Tahlequah)

email: youngstire@cablone.net

Young's Tire

S&S, LLC

Established

1973



KENDA



Most
Brands

918-961-3898

Horizon Roofing & Construction, Inc.

Shannon Walker



Truck, Tractor & Auto
Fast Efficient Service

Sam's Tire Shop

Mon-Fri 8 to 5

Sat 8-12

(918) 256-7591

436 S. Wilson

Vinita, OK. 74301-4246

WE PRIDE OUR BUSINESS
ON SERVICE & HAVING
PARTS FOR ALL MODELS
OF VERMEER BALERS



Deweze

EUBANKS JORGENSON

1-888-833-7042

Service is Our

#1 Priority!

CRAIG EUBANKS

MOBILE: 918-961-8048

443858 E 20 RD.

WELCH, OK 74369

LIVINGSTONE PROPANE & VOGEL OIL

OFFICE #918-256-8461 / CELL #918-244-1344

STEPHEN PROCTOR
MANAGER

livingston@okfuels.net vogeloil@att.net

**437294 East Highway 60
Vinita, OK 74301**

Up-coming Events

TOPS #570 We meet 9am to 11am Monday morning at Mt. Olive Lutheran Church in Miami 2337 N. Main St. "Taking off pounds sensibly!"

TOPS #567 meet every Thursday at 10am 433 N Mississippi in Nowata.

TOPS #506 in Miami Heavenly Winds Worship Center meet every 6pm Monday evening. For more info call Susan Walls at 918-540-0570

Every 4th Saturday of the month Veteran's Support Group: Veterans for Veterans. Have you served in the military? Are you struggling with readjustment? Anxious about the future? Struggling to connect with friends and family? Struggling with school? WE CAN HELP! Free veterans support group at 10am every 4th Saturday of the month. The Landing 502 West Corner Fairland, Ok. For more information call Larry Boyd (918) 541-7592 or Cindy (918) 676-3228.

Food Truck Wednesdays —Every Wednesday, grab some tasty eats and gather on the grounds of Guthrie Green. During Food Truck Wednesdays, lunchtime transforms into a community-wide affair, with roaming food trucks posting up at this Tulsa park. While you dine on delicious food, be sure to enjoy the live music and fresh air. Guthrie Green 111 E Brady St Tulsa, OK 74103 Phone: 918-574-2421

Chelsea Dance and Jam Session—Every Friday Night 6:00 pm—9:00 pm—Bring a dish for potluck at 6:30 pm. Musicians are welcome. Civic Center 618 Pine street Chelsea, OK 74016

Big Cabin Senior Exercise Program—Fitness program for seniors held at the Big Cabin Baptist Church gym three times a week, Monday, Wednesday and Friday, from 10 to 11 a.m.

American Legion Post 178 in Grove, OK – Bingo every Saturday evening at 6pm. Family atmosphere. Contact Lee Cathy for any questions at: 901-487-9060

PRYOR DANCE—Every 1st. And 3rd. Thursday of the month. 6:15 pm—9 pm—Mayes County Nutrition Center 851 SE 9th Pryor (just east of 9th and Elliott intersection)

Oct. 19 - Oct. 24 2019 Bag O' Books Sale - Fill a Paper Bag with any Items from the Book Sale Tables. Sat. Oct. 19 \$5.00, Mon. Oct. 21 \$4.00, Tue. Oct. 22 \$3.00, Wed Oct. 23 \$2.00, and Oct. 24 - 26 \$1.00. Prices on individual items: \$1 each for hardbound, audio, video and 25¢ each for paperbacks. Vinita Public Library 215

SUDOKU PUZZLES

Fill in the grid with digits in such a manner that every row, every column and every 3X3 box accommodates the digits 1-9, without repeating any.

		4						
1		5	2	4			8	
7			6	5	8	2	4	
					2	4		
	2			8			7	
		6	1					
	3	8	4	7	5			6
	4			1	6	8		7
						9		

Hardship level: Moderate

5		4						
2		7			9	6	3	
	6			3				4
8	1			6			5	
			9		7			
	7			2			4	1
6				7			2	
	4	1	2			5		8
						4		7

West Illinois Avenue Vinita, OK Hours: 11am - 5:30pm
Weekdays, 11am - 2:30pm Saturdays. No Credit/Debit
Cards Accepted - Cash or approved check only. Contact
918-256-2115-Email library@cityofvinita.com

Sep 20, 2019 - Nov 02, 2019 The Hex House - Travel to
Tulsa for The Hex House, northeast Oklahoma's extreme
haunted attraction. The Hex House is an intense, multi-
element, walk-through haunted house attraction themed
around a dark chapter in Tulsa's haunted past. The origi-
nal Hex House was involved in a 1944 police investiga-
tion surrounding a small casket buried in the backyard of
a Tulsa house and two young women 5610 W Skelly Dr
Tulsa, OK 74133 Toll Free: 877-980-7882

Sep 24, 2019 - Nov 09, 2019 Pumpkin Festival at Shep-
herd's Cross - Celebrate fall with pumpkins, hayrides
and harvest educational activities at Shepherd's Cross,
an authentic working farm in Claremore. Come out and
select a pumpkin from truckloads available in all shapes
and sizes at the Pumpkin Festival at Shepherd's Cross.
Guests can also take home straw bales and corn stalks
for fall decorating. At this annual pumpkin festival, walk
the hay maze, create a scarecrow, take a hayride, pet the
animals in the petting zoo and make memories. Enjoy
lots of fun games and activities for the whole family,
farm demos and festive fall story time while celebrating
the harvest season Shepherd's Cross 16792 E 450 Rd
Claremore, OK 74017 Phone: 918-342-5911.

Sep 27, 2019 - Nov 02, 2019 Sep 27, 2019 -The Asylum
- Uncover the disturbing secrets held within The Asylum
in Nowata, a terrifying haunted attraction that will leave
you frightened for days. The story goes that this building
is a former mental institution that was the site of a horri-
ble fire decades ago, and man details are unknown, in-
cluding if there were any survivors. Experience The
Asylum at the risk of your own sanity, because you'll
see scary things beyond your wildest nightmares, based
on the unrestricted operations of sanitariums in the
1940s. A VIP pass will be available on Halloween night
for an exclusive tour of The Asylum. Please note: Chil-
dren under 13 are not allowed in The Asylum without a
parent or guardian. 304 W Cherokee Ave Nowata, OK
74048 Phone: 918-559-5049

Sep 27, 2019 - Oct 26, 2019 Haunted Castle Halloween
Festival - The Castle of Muskogee is Oklahoma's largest
haunted attraction with over 62 acres of spine chilling
thrills and excitement. Come celebrate more than 20
years of thrills with a combination of indoor and outdoor
attractions with activities, vendors, games, shows, rides,
shops, food and fun for all ages. There are 11 spooktacu-
lar events to test your nerves in the scariest and rated
one of the best haunted attractions in the state. The Cas-
tle of Muskogee 3400 W Fern Mountain Rd Muskogee,
OK 74401 Phone: 918-687-3625 Toll Free: 800-439-

0658

Sep 28, 2019 - Nov 03, 2019 Oklahoma Heritage Farm
Fall Festival Maze & Pumpkin Patch - Celebrate fall
with a trip to Oklahoma Heritage Farm for the annual
festival that features a pumpkin patch and an incredible
maze. Kids of all ages will love picking out a pumpkin in
the pumpkin patch and visitors can spend hours having
fun with over thirty acres covered with games, rides, ac-
tivities, animals and entertainment included in the gen-
eral admission price. A real working farm transforms
into a great family outdoor adventure for six weeks every
fall. 38512 US Hwy 75 Ramona, OK 74061 Phone: 918-
371-7887, 918-346-8738

Oct 04, 2019 - Oct 26, 2019 Psycho Path Haunted At-
traction - Travel to Sperry for the Psycho Path Haunted
Attraction and prepare to be terrified. Enter woods
shrouded by fog and venture deep into the darkness
where ghoulish creatures are waiting behind every twist
and turn. Psycho Path offers visitors Hollywood-caliber
scenes and over 40 acres of wooded terror. This haunted
house attraction features high-intensity scares in an out-
door 1517 E 106th St N Sperry, phone 1 918-288-7685-
918-637-9445 Fax: 918-371-6965

Oct 04, 2019 - Oct 31, 2019 Psycho Path 1331 at Death's
Door Haunted Attraction - Killing Frost Productions,
LLC presents "1331 At Death's Door" haunted attraction
for the 2019 Halloween season. Each year, Killing Frost
brings scary surprises and frightening creatures to the
Washington County Fairgrounds in Dewey. Come see
entirely new additions and prepare yourself for a fright-
fully good time. "1331 At Death's Door" Haunted Attrac-
tion Schedule: October 4, 5, 11, 12, 18, 19, 25, 26, 30 &
31. Ticket booth open from 7:30-11:30pm.

Do You have an event that you would like to share ?
Community Links of Chelsea
1100 Walnut/PO Box 85
Chelsea, OK. 74016
Ph: 918-789-2862
Fax: 918-789-5296
Email: links@links.community-options.net

DATA MASTERS: Steven Burdick and Eric Peachey



By Breanna McDowell



Sprucing Up for Spring

When the snow melts and the ground thaws, it's time to plant your garden. There are twenty objects hidden among the busy children. Can you find the ice-cream cone, mouse, crayon, clothespin, trumpet, toothbrush, glove, hammer, clock, paper clip, feather, comb, chicken, candle, teacup, sock, seal, frog, fish, and book?



Getting to know the Lutherans

A New Set of Clothing

At a recent school chapel service, the principle, wearing a fine suit and tie, began by saying, “What we wear is often a statement of who we are. We dress to please those around us. We look good on the outside.” Then he took off his coat. Written many times in black on his white shirt was the word sin. “This is what we all wear,” he said. “We look for ways to cover it up. But we cannot rid ourselves of sin.”

Jesus entered our world of sin to give us His robe of righteousness. He makes us right before our heavenly Father. “I have put on you My new set of clothing,” Jesus says. “In place of your sin-stained apparel, I have covered you with My blood, shed for you, dressing you in the garment of salvation, and clothing you in My righteousness.”

Is this not reason to be overwhelmed with joy? Simply put, we are great sinners, yet Christ is the great Savior! Through Baptism, He is our robe of salvation. Now that we live in Him, Christ also helps us who are weak, putting off the things that would pull us away from Him, and putting on our new selves, which are renewed daily in Him.

Come visit us at one of the area Lutheran churches.

DATA MASTER: Heather Conn

<p>Messiah Lutheran Church 460 N. Wilson, Vinita, OK. Sunday School and Bible Class 9:00 a.m. Worship 10:00 a.m. 918-256-3223 Email: messiahvinita@aol.com</p>	<p>St. Paul Lutheran Church Washington and Pine, Fairland, OK. Sunday School and Bible Class 9:15 a.m. Worship 10:30 a.m. 918-676-3059 Email: stpaulluthch@aol.com</p>
<p>Bethlehem Lutheran Church 6911 West 380 Road, Adair, OK 74330 Worship 9:00 a.m. 918-785-2994 Sunday School and Bible Class 10:15 a.m.</p>	<p>Immanuel Lutheran Church 706 Rockwood Drive, Grove, OK. Worship 9:30 a.m. 918-786-4585 Website: www.lutheransonline.com/lo/Groveok</p>
<p>Mt. Olive Lutheran Church 2337 North Main, Miami, OK 74354 Worship 2:00 p.m. (918) 542-4681 Sunday School and Bible Class 3:00 p.m. Email: mtolive@cablone.net</p>	<p>Redeemer Lutheran Church 220 N. Seminole, Claremore, OK. Sunday School and Bible Class 9:00 a.m. Worship 10:30 a.m. 918-341-1429 Email: rluther@sbcglobal.net – Website www.rlccok.org</p>
<p><i>Guests are always welcome. See you Sunday at worship.</i></p>	<p>St. John Lutheran Church 607 SE 9th Street, Pryor, OK. Sunday School and Bible Class 9:15 a.m. Worship 10:30 a.m. 918-825-1926 Email: stjohncpyor@sbcglobal.net - Website: www.stjohncpyor.org</p>

Crossword Puzzle

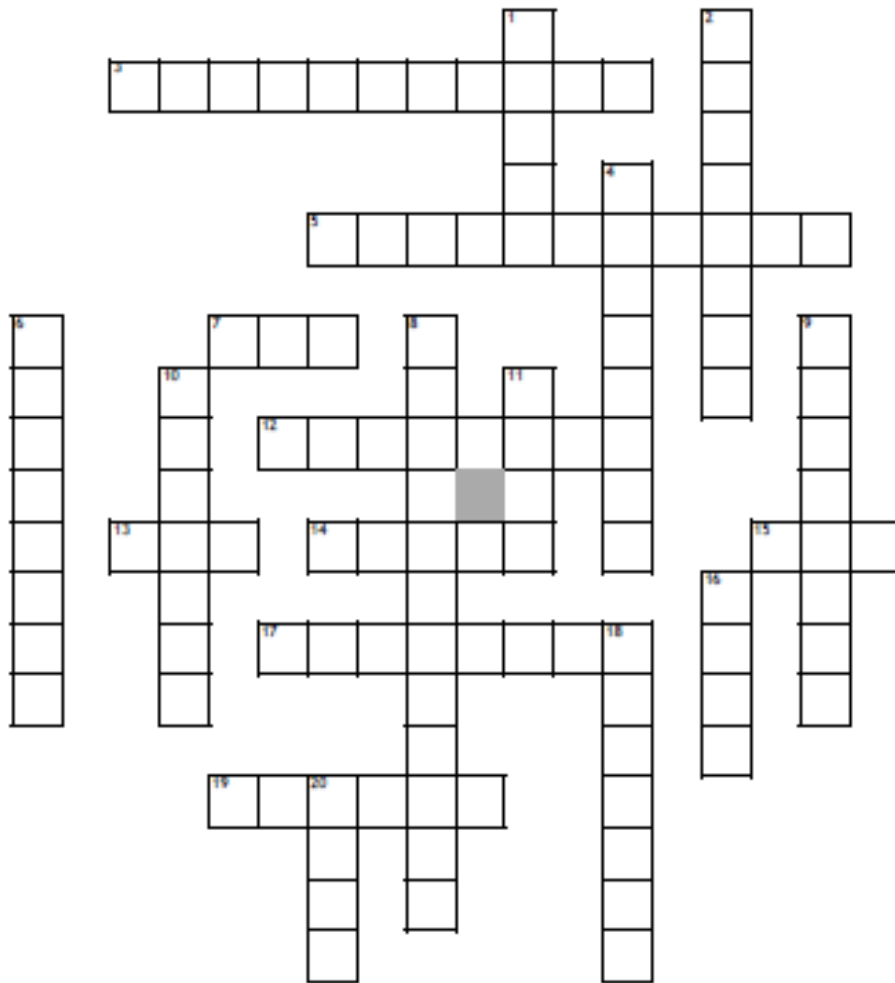

Across

- 3. 1989 Halloween-themed horror film
- 5. *Popular tune around Halloween
- 7. Black Halloween animal
- 12. "Superman" character
- 13. Black Halloween animal
- 14. Halloween" movies character Michael ____
- 15. Halloween
- 17. 'Queen of Country Music'
- 19. "The Father of Country Music" Rodgers

Down

- 1. 'Halloween,' for Jamie Lee Curtis
- 2. Member of DC Comics' Legion of Super-Heroes
- 4. "Batman and Robin" villain
- 6. Basic Halloween costume
- 8. country Music
- 9. 'King of Country Music'
- 10. "Opposite" planet in Superman lore
- 11. Black Halloween critters
- 16. '60s NASA target
- 18. "Batman" villain
- 20. "Monster ____" (Halloween hit)

By: Eric Peachey and Steve Burdick

Solution is printed in page 37

Word Search Puzzle

N R E X T R A C T I O N Y P A V Y A L X Y R P Q
 O Y N H G U H R A E B G V V E A I A G A H G Q
 I O N G X O A W L A O S E V I E W P O I N T E W
 S X T U O D N A R E V O N L U T H M V O I K
 A V G V G R T G U N D P E V A W Y T B V N N D A
 U K N N E E Q H P D N T R K U I H K G D R I F W
 S H I A R S P I N F R H A E W P L N D V N U M
 R T P T N E N S A G Q E L V P Z O Y I U W D R V
 E R S U K L C W T N M O K B B V S Z D F I I T A
 P I A R H P O I T I Q R N R C U O U N C S V H
 E B R E E I N T A R T Y O A T Y L D E S D I E F
 I G G P S C V Z C E U D W W T G I E T N O D R M
 S N P E T N I E K T L P L L N O H V N P M U W Y
 N I B R R I C R I N S V E I E L P I O C C A E Y
 A C H S I R T Z N U A N D N M O R C O T L S T
 M A O O V P I U G O N U G G A T U T E R X I T I
 O F L N I O G F C S B E E R N E N N N H S K D
 H I M I N I N U N Q P S H E O P O S H O M W D
 A E F F G C S V G E I T O P A Q C Z U L S Z I
 L D N I R D E S C E N T U B M Y P I S D T V U
 K A I E C U Z P X R H N D N E V Q Z D K I O Z Q
 O H E D N K C D N B G I T T V I G I E N C L U
 K D Q G I L S K O W E N E Q L L T N V R G K G V
 L O A F E B P V Q N Q C S C C G G N I G G U H K

DESCENT	EXTRACTION	BIRTH	STOCK
Philosophy WAY	GENERALKNOWLEDGESTUDIES	CREED	WISDOM
PERSUASION	ONTOLOGY	CONVICTIONS	THEORY
VIEWPOINT	PRINCIPLES	Contrived	LATER
OWEN	CORNHUSKER	TULSANS	OKLAHOMANS
SWITZER	OVER AND OUT	VIN	FURTHERWEST
ENCOUNTERING	BRAWLING	GRASPING	STRIVING
HOLDING	HUGGING	BEAR HUG	FACING
ATTACKING	PIN	CONTENDING	QUIDDITY
TEMPERAMENT	NATUREPERSONIFIED	INDIVIDUALISM	

CryptoQuote Puzzles

Title: Knowing Self **Quote From:** Dalai Lama

A	B	C	D	E	F	G	H	I	J	K	L	M	N	O	P	Q	R	S	T	U	V	W	X	Y	Z
																			Y	T					

T _____ **T**
 Y A U A V Z P X C A V X O X J I F O G D C X G Y X C
V _____ **T** _____ **T** _____ **T** _____ **T** _____
 T F U Y A C E Y B G V Y A U A V Z P X C Y B A P O G
 _____ **T T** _____
 V K O F V G R G Y Y J X

Title: Science Fiction **Quote From:** Steven Spielberg

A	B	C	D	E	F	G	H	I	J	K	L	M	N	O	P	Q	R	S	T	U	V	W	X	Y	Z
		V	W									C					Z								

_____ **C C** _____ **D M** _____
 O X J Q E E B S M E F M V M V O H S W M C O H H
 _____ **S C** _____ **C** _____ **C** _____
 M B L Z V O M Q V M L O V E O B Q

Title: Is Music Math? **Quote From:** Bruno Mars

A	B	C	D	E	F	G	H	I	J	K	L	M	N	O	P	Q	R	S	T	U	V	W	X	Y	Z
							H					S					Y								

M S I I S M I S S I
 S C Y H I H Y A B Z S N Z D H Z Y Y I H U A I U
 _____ **M I I** _____ **S** _____
 V B C E U U X S H R H A Q Z D U Y Z C K K
 _____ **I I S** _____
 C X C A Z H O H Z F O B G Y C X B A V B C
 _____ **I M S I S I I** _____
 B J H Z F U I B S U Y Z D H Y H A I J U T H F O U
 _____ **I** _____
 X B Z H B A

Multiple Choice Puzzle

Community Links Multiple Choice Puzzle Oct. 20, 2019

1. Reluctant to abandon first solemn undertaking
A. ROAD
C. ARCH
B. BADE
D. OATH
2. In 1927, who became the first man to fly solo and non-stop across the Atlantic?
A. Amelia Earhart
C. Bessie Coleman
B. Charles Lindbergh
D. Richard Bong
3. Stratus, Cirrus & Cumulus are names for different types of what?
A. Storm
C. Clouds
B. Tornado
D. Lightning
4. Movie character with multiple personalities
A. SECONDS
C. SYBIL
B. DYNAMIC
D. NONE OF THE ABOVE
5. Rivers running through Vietnam
A. Thach Han River
C. Danube
B. Mekong
D. A and B
6. A many-headed serpent in Greek mythology
A. TRALA
C. HYDRA
B. PAGODA
D. EVE

By: Steven Burdick and Eric Peachey

Solution on page 29

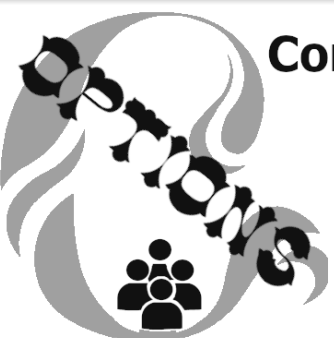

Community Options, Inc. website is operational

Pay a visit to our website to learn about what we are doing and how you can help others by getting involved.

If you are seeking for employment you can apply for your desired position with us online.

our website can be accessed at:
<https://community-options.net>

Hashi (Bridge Building) Puzzle

Puzzle Rules: The goal is to connect all of the islands by drawing a series of bridges between the islands. The bridges must follow certain criteria: 1) They must begin and end at distinct islands, travelling a straight line in between. 2) They must not cross any other bridges or islands. 3) They may only run orthogonally (i.e. they may not run diagonally). 3) At most two bridges connect a pair of islands. 4) The number of bridges connected to each island must match the number on that island. 5) The bridges must connect the islands into a single connected group.

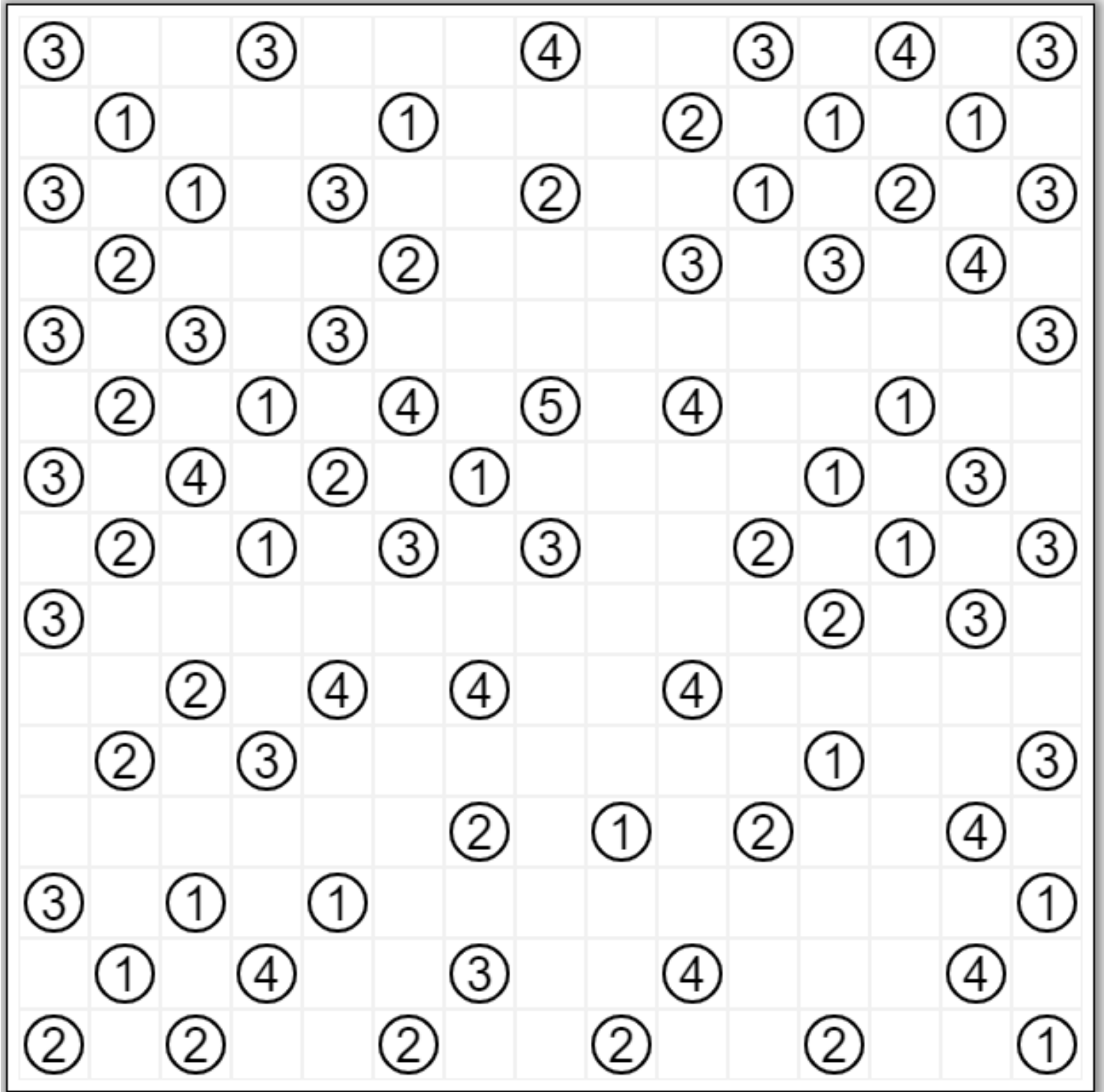

Some Riddles

1. A 400 yard long train, travelling at 30 mph, enters a 4.5 mile long tunnel. How long will elapse between the moment the front of the train enters the tunnel and the moment the end of the train clears the tunnel?
2. What do you get when you cross a fish with an elephant?
3. Dipping, glinting, gliding by, Rainbow-fretted, wrought of breath. I live only while I fly – Earth's rough kiss my sudden death.
4. If there are four sheep, two dogs and one herdsman, how many feet are there?
5. You just bought a cute rabbit at a pet store. The rabbit can breed once every month, and deliver 7 babies at a time. How many rabbits do you have after 12 months?
6. A train leaves from Halifax, Nova Scotia heading towards Vancouver, British Columbia at 120 km/h. Three hours later, a train leaves Vancouver heading towards Halifax at 180 km/h. Assume there's exactly 6000 kilometers between Vancouver and Halifax. When they meet, which train is closer to Halifax?
7. How many sides does a circle have?
8. When does Halloween come before Valentine's day?
9. Billy was born on December 28th, yet his birthday is always in the summer. How is this possible?
10. What kind of tree can you carry in your hand?
11. Every night I'm told what to do, and each morning I do what i'm told. But I still don't escape your scold.
12. If you have me, you want to share me. If you share me, you haven't got me. What am I?
13. What is the first thing a storm cloud puts on after a shower?
14. What comes once in a minute, twice in a moment, but never in a thousand years?
15. A man was driving a black truck. His lights were not on. The moon was not out. A lady was crossing the street. How did the man see her?

DATA MASTER: Breanna McDowell

Answers are printed on page 29

TOM CAT CORNER

- Hickory Smoked BBQ
- Custom Meat Smoking
- Catering
- Bait & Tackle
- Hunting & Fishing License
- Deli
- Groceries
- Souvenirs
- Pizza
- Beer



Friendliest staff in Grove 😊

COMPETITIVE GAS PRICES

Hours
Sun & Mon
6 AM - 11 PM
Tues - Sat
24 hrs

Hwy. 59 North • Grove, OK **918-786-6622**

LANGLEY DRUG

1631 N. 3rd Langley, OK. 74350

918-782-3271

Hours:

Mon-Fri 9:00 am to 6:00 pm

Sat 9:00 am to 1:00 pm

Accept most insurances Medicare part B and D

Julia Brown, Pharmacist

Western Wear * Boots * Tack * Laundry Drop

Langley

Western Store

20x
Cruel Girl
Lawman
Roper
American West

Ariat|Justin|Tony Lama|Lucchese|Minnetonka

HWY 82|Langlev, Oklahomna

918-782-2726

Open 9:30 - 6:00 pm * Closed Sunday

langley_western_store@yahoo.com

P.O. Box 730

1116 N 3rd. street

Langley, OK 74350

Multiple Choice Puzzle Solution

Community Links Multiple Choice Puzzle Oct. 20, 2019

Riddles Answers

1. 9 minutes and 27.2727 seconds.
2. Swimming trunks
3. A soap bubble
4. Sheep have hooves; dogs have paws; only people have feet.
5. One, it takes two rabbits to breed.
6. Both trains would be at the same spot when they meet therefore they are both equally close to Halifax.
7. Two. The inside and the outside.
8. In a dictionary.
9. Billy lives in the Southern Hemisphere.
10. A palm
11. An alarm clock.
12. Secret
13. Thunderwear
14. The letter "M".
15. It was a bright, sunny day.

DATA MASTER:
Breanna McDowell

1. Reluctant to abandon first solemn undertaking

- A. ROAD
- C. ARCH

- B. BADE
- D. OATH

2. In 1927, who became the first man to fly solo and non-stop across the Atlantic?

- A. Amelia Earhart
- C. Bessie Coleman

- B. Charles Lindbergh
- D. Richard Bong

3. Stratus, Cirrus & Cumulus are names for different types of what?

- A. Storm
- C. Clouds

- B. Tornado
- D. Lightning

4. Movie character with multiple personalities

- A. SECONDS
- C. SYBIL

- B. DYNAMIC
- D. NONE OF THE ABOVE

5. Rivers running through Vietnam

- A. Thach Han River
- C. Danube

- B. Mekong
- D. A and B

6. A many-headed serpent in Greek mythology

- A. TRALA
- C. HYDRA

- B. PAGODA
- D. EVE

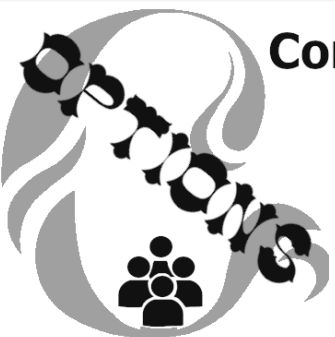

Community Options, Inc.

website is operational

Pay a visit to our website to learn about what we are doing and how you can help others by getting involved.

If you are seeking for employment you can apply for your desired position with us online.

our website can be accessed at:
<https://community-options.net>

By: Eric Peachey and Steven Burdick



Library News

CATOOSA PUBLIC LIBRARY

105 E. Oak (918) 266-1684

Hours:

Monday thru Thursday: 9am to 7pm

Friday: 9am to 12pm & 1pm to 3pm

Saturday: 10am to 2pm

Closed Sunday

CHELSEA PUBLIC LIBRARY

618 Pine (918) 789-3364

Hours:

Tuesday: 10:00am to 7:00pm

Wednesday, Thursday & Friday: 10:00am to 4:00pm

Saturday: 9:00am to Noon Closed Sunday & Monday

CHOUTEAU PUBLIC LIBRARY

307 W Main Phone: 918-476-4445

Hours:

Mon - Fri - 10AM to 5PM

Closed Saturday & Sunday

DELAWARE COUNTY LIBRARY

429 S. 9th St. Jay, Oklahoma (918) 253-8521

Web: www.eodls.lib.ok.us/jay.html

Hours:

Mon., Wed., & Fri. 9:00am to 6:00pm

Tues. & Thurs 9:00am to 8:00pm

Sat. 9:00am to 1:00pm

Closed Sundays and Holidays

GROVE PUBLIC LIBRARY

1140 NEO Loop (918) 786-2945

Toll free in the 918 area code: 1-888-291-8150

Fax: (918) 786-5233

Hours:

Mon., Wed., & Fri.: 8:30am-5:00pm

Tues. & Thurs.: 8:30am-9:00pm

Sat. 8:00am-12:00pm

Closed Sunday

LANGLEY PUBLIC LIBRARY

325 W Osage Ave. (918) 782-4461

Hours:

Mon.-. 1:00pm to 7:00pm

Tue.-Fri. 9:00am to 12:00pm

And 1:00pm to 5:00pm

Closed Sat. & Sun.

MIAMI PUBLIC LIBRARY

200 N. Main (918) 541-2292

Hours:

Sun. 1:00pm

Mon., Wed., Thurs., 9:00am to 8:00pm

Tues., Fri., Sat., 9:00am to 5:00pm

NOWATA CITY-COUNTY LIBRARY

224 S. Pine (918)273-3363 Fax: (918)273-1818

Hours: Mon-Fri 10^{am} -6^{pm}; Sat 9^{am}-12^{pm}

PRYOR PUBLIC LIBRARY

505 E. Graham, Pryor 918-825-0777

Hours:

Monday & Thursday: 1:00 PM-9:00 PM

Tuesday, Wednesday & Friday:9:00AM-5:00PM

SALINA PUBLIC LIBRARY

420 E. Ferry St. (918) 434-8001

Hours: Tue. 12pm-7pm, Wed. 12pm-5pm,

Thurs. & Fri. 10am-5pm

Closed Saturday, Sunday & Monday

TALALA AREA PUBLIC LIBRARY

106 W Watova St. (918) 275-4540

Hours:

Monday - Friday 2pm to 5pm

Monday and Thursday evening 6pm to 9pm

Saturday 11am to 2pm

VINITA PUBLIC LIBRARY

215 W. Illinois (918) 256-2115

Hours:

Mon., Tues., Wed., & Fri. 11:00am to 6:00pm

Thurs. 11:00am to 7:00pm

Sat. 11:00am to 3:00pm

Closed Sunday

WILL ROGERS LIBRARY

1515 N. Florence, Claremore OK (918) 341-1564

Hours:

Mon & Tues. 9:30am to 8:00pm

Wed. & Thurs. 9:30am to 6:00pm

Fri. & Sat. 9:30am to 5:00pm

30 Closed Sunday

THE LITTLE GREEN SHOP

301 E. Layton Chelsea, OK.



Across From Harp's

918 - 789 - 3676



**FISHING EQUIPMENT & SUPPLIES
MINNOWS * NIGHT CRAWLERS
SHRIMP * CHICKEN LIVER
CUT SHAD * RABBIT LIVER
WHOLE SHAD & MORE
DRINKS, SNACKS**

**Route 66 items for sale
6 POUND BAG OF ICE \$1.50
20 POUND BAG OF ICE \$3.75**

A Good Community To Live In!

CHELSEA TERRACE

FOR MORE INFORMATION CONTACT OUR
Rental Office at (918) 789-5200
302 Charlotte Street, Chelsea, OK.

\$200.00 DEPOSIT

\$450 1 bedroom ~ \$500 2 bedroom
ground floor/ handicap accessible
washer/dryer hookup

Paid: water, sewer, garbage, & lawn care
Provided: refrigerator, stove

3 Bedroom House with One Car Garage
1101 square feet

\$590.00 monthly ~ \$350.00 deposit ~ washer/dryer hookups ~ Provided: refrigerator, stove

An Equal Housing Opportunity

SECTION 8 HOUSING VOUCHERS ACCEPTED

Community Links Of Chelsea

1100 Walnut

Chelsea, OK 74016

Ph: (918) 789-2862

Fax (918) 789-5296

Email:

commuitylinks1999@yahoo.com

Please give us feedback at:

<http://links.qitg.net>

Printing: Business Cards, Letterheads – Flat or raised print available. Brochures, Business Forms, and Personalized greeting cards.

Advertising: Links Newsletter, Bi-Monthly distributed by persons with developmental disabilities, Connecting Communities at an affordable rate.

Office Supplies: Self Inking Stamps, Paper products, Toner Cartridges, Printer Cartridges. If we don't have it in stock we will order for you. Most orders complete in 3 days

SUNKISSED



Floral & Greenhouse

Anita Smith

www.sunkissedfloral.com

918-542-1381

1800 A NW

800-352-8274

Miami, OK 74354

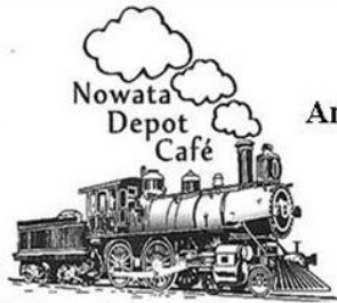

Nowata
Depot
Café

Anthony M. & Lisa K. Gray
Owners

7:00am-3:00pm Sun.

7:00am-8:00pm Mon.-Thurs.

7:00am-8:30pm Fri.

Closed Sat.

127 S. Oak Street

Nowata, OK 74048

918-273-2500

Welcome to Mayes County!

For over 70 years, Mayes County Propane has been providing quality service to customers in Pryor, OK and the surrounding areas. We are the preferred propane supplier to residential, commercial and agricultural customers in our area.



MAYES
COUNTY PROPANE

4665 West Hwy 20 • Pryor, OK 74361

For propane services you can trust and rely on, contact Mayes County Propane today! We look forward to the opportunity to serve all of your propane needs.

Phone 918-825-2433
Toll Free 1-800-722-2669

www.propanemcp.com
propanemc@yahoo.com

compassionate about care.
PASSIONATE ABOUT LIFE.



GSH
GOOD SHEPHERD HOSPICE

Free Medicare Benefit

We believe that care during a terminal illness is more than just a diagnosis and treatment.

It's a daily exercise in making this moment, this day... the very best it can be.

918.786.6182

800.787.2226

www.goodshepherdhospices.com

CryptoQuote Puzzles Solution

Title: Knowing Self **By:** Dalai Lama

To conquer oneself is a greater victory than to conquer thousands in a battle

Title: Science Fiction **By:** Steven Spielberg

I want to be the Cecil B. DeMille of science fiction.

Title: Is Music Math? **By:** Bruno Mars

Music is not math. It's science. You keep mixing the stuff up until it blows up on you, or it becomes this incredible potion

By: Eric Peachey and Steven Burdick

Hashi (Bridge Building) Puzzle Solution

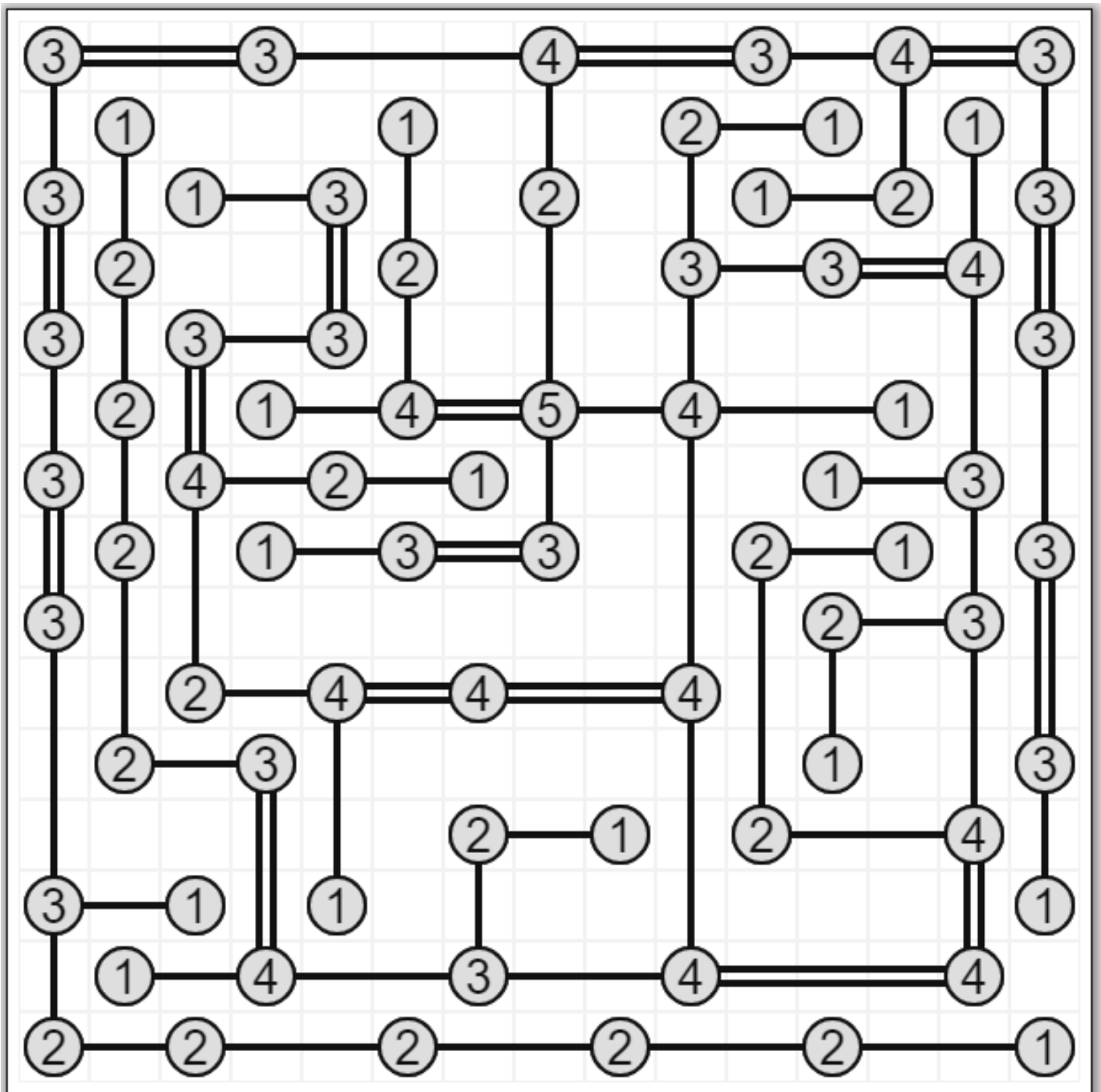

By: Eric Peachey and Steven Burdick

Word Search Puzzle Solution

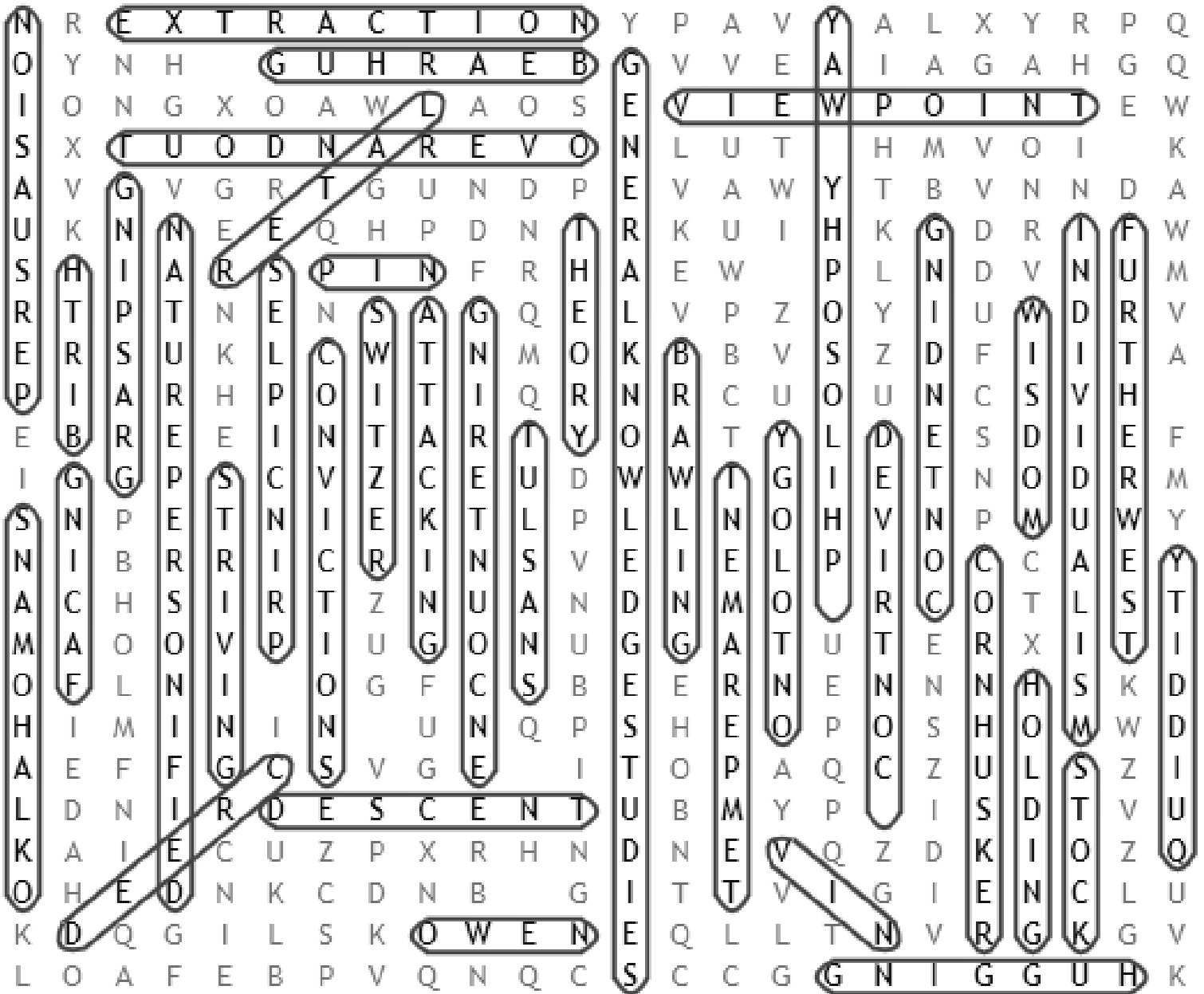

By: Eric Peachey, and Steven Burdick

INNOVATIONS IN HAIR
 COMPLETE HAIR CARE
 MANICURES & PEDICURES
 918-825-2570
 459 S. Wood Pryor, OK 74361

Countryside Farm & Home
918-476-0537
13108 S. 4293
Chouteau, OK 74337
 Discount Tools, Kitchenware,
 Indoor and Outdoor Furniture,
 Sporting Goods, Hunting,
 Camping, and Fishing gear

HERE TO HELP YOU GROW
a brighter financial future

 Lakeside State Bank

"Big enough to serve you, small enough to know you."



CHELSEA | 516 Walnut | 918.789.2581 | OOLOGAH | 6695 E. 400 Rd. | 918.443.2474 | www.lakesidebankok.com

Sudoku Puzzle Easy Solution

2	8	4	3	9	1	7	6	5
1	6	5	2	4	7	3	8	9
7	9	3	6	5	8	2	4	1
3	5	9	7	6	2	4	1	8
4	2	1	5	8	9	6	7	3
8	7	6	1	3	4	5	9	2
9	3	8	4	7	5	1	2	6
5	4	2	9	1	6	8	3	7
6	1	7	8	2	3	9	5	4

Sudoku Puzzle Moderate Solution

5	3	4	7	8	6	9	1	2
2	8	7	1	4	9	6	3	5
1	6	9	5	3	2	8	7	4
8	1	2	3	6	4	7	5	9
4	5	3	9	1	7	2	8	6
9	7	6	8	2	5	3	4	1
6	9	5	4	7	8	1	2	3
7	4	1	2	9	3	5	6	8
3	2	8	6	5	1	4	9	7

BY: Nikki Hamilton

Crossword Puzzle Solution

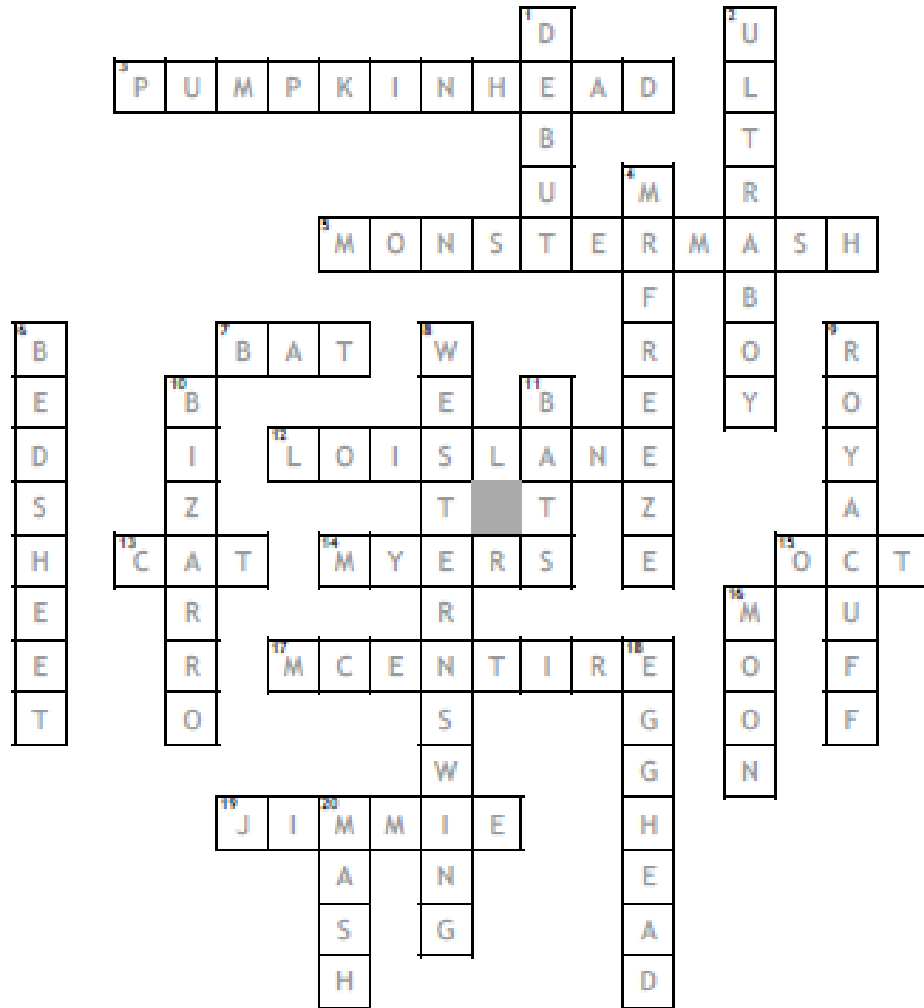

Across

- 3. 1989 Halloween-themed horror film
- 5. *Popular tune around Halloween
- 7. Black Halloween animal
- 12. "Superman" character
- 13. Black Halloween animal
- 14. Halloween" movies character Michael ____
- 15. Halloween
- 17. 'Queen of Country Music'
- 19. 'The Father of Country Music' Rodgers

Down

- 1. 'Halloween,' for Jamie Lee Curtis
- 2. Member of DC Comics' Legion of Super-Heroes
- 4. "Batman and Robin" villain
- 6. Basic Halloween costume
- 8. country Music
- 9. 'King of Country Music'
- 10. "Opposite" planet in Superman lore
- 11. Black Halloween critters
- 16. '60s NASA target
- 18. 'Batman" villain
- 20. "Monster ____" (Halloween hit)

**We would like to
thank the following
Businesses for
distributing LINKS**

Adair

Casey's General Store
Woodshed

Afton

Afton City Hall
Evans Roofing

Big Cabin

Big Cabin Senior Citizens

Chelsea

Bank of Commerce
Chelsea Family Pharmacy
Chelsea Library
Chelsea Post Office
Chelsea Sr. Citizens
Chelsea Terrace
Community Links
Dollar General
Harp's Grocery
Jiffy Mart
Lakeside State Bank
Little Green Shop
Main Street Diner

Chouteau

Cherry's Chouteau Mall
Chouteau Public Library &
Senior Citizens Center
Dutch Pantry
Marvin's Grocery
Pizza Corral

Claremore

Bill's Sporting Goods
Brook Field Nursing Home
Casey's
Claremore DHS
Claremore Nursing Home
Claremore Senior Citizen's
Claremore Veteran's Center
Classy Cuts and Wigs
Kum N Go (W Will Rogers)
Kum N Go E Hwy 20
Midco Clothes & More
Stillwater Milling
Emerald Care Center

Commerce

Eastwood Manor

Fairland

Fairland Sr. Citizen's

Grove

Eagles Landing
Drakes
Grand Prosthetics & Artificial
Limbs
Grandwood
Mr. M's Convenience Store
Grove Sr. Citizens
Harps Grocery
Tom Cat Corner

Jay

Sinclair Station
Delaware County Library
Jay Senior Citizen's

Ketchum

Buddy's Foods
Woodshed

Langley

4 State Insurance
Langley Drug
Reasor's Grocery Store
Langley Western Store

Miami

Marvin's Grocery
Windridge
Wal-Mart Supercenter

Nowata

D&L's
Homeland
Nowata Depot Café
Nowata Senior Citizens Cen-
ter
Ranch Supply
Reid's Discount Pharmacy

Oologah

Pump - N - Petes #15
Tacora Mart (Conoco)

Pryor

Innovations in Hair
Mayes Co. Nutritional Center
Wilkerson Real Estate
Pryor Library
Shady Rest Nursing Home
Paulie's Donuts
The Book Exchange

Spavinaw

T-General Store

Vinita

Burrough Manor
Carter's IGA
Grand Lake Mental Health
Heartsworth House
Midco Clothes & More
Sam's Tire
Veterans Clinic
Vinita Sr. Center
Vinita DHS
Vinita Post Office
Wood Shed
Young's Tire

Welch

Welch State Bank

Winganon

Winganon Bait Shop



Community Options, Inc.
website is operational
Pay a visit to our website to learn about what
we are doing and how you can help others by
getting involved.
If you are seeking for employment
you can apply for your desired
position with us online.

our website can be accessed at:
<https://community-options.net>

Vinita Muffler & Radiator

Steven Smith - MD/DHT
"Over 90 years Experience"

**Fast, Professional Work
the First Time!**

- Cat-Back Dual Exhaust
- Catalytic Converter Service
- Gas Tank Cleaned,
- Repaired, Lined & Coated
- Radiators - Plastic or Brass

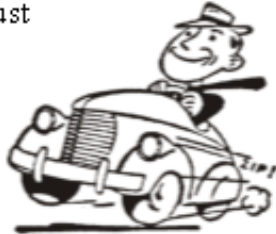

(918) 256-6969

**502 N. Wilson
Vinita, OK 74301**

We can mail current or past issues to you. The cost of shipping and handling is \$2.00 per issue. If you would like to receive every issue without delay you may pay \$24.00 shipping and handling cost for 6 months or \$48.00 shipping and handling cost for full year.

LINKS

Information

The Links Paper comes out twice a month, the 5th and the 20th of every month. We offer many different advertising options and have competitive pricing. Should you be interested in placing an ad with us you can contact us at the phone number or the email provided below.

Deadlines for ad submission:
5th issue: 25th of previous month
20th issue: 10th of the same month

**Community Links of Chelsea
1100 Walnut
Chelsea, OK 74016
communitylinks1999@yahoo.com
(918) 789-2862
Open:
Monday - Friday 8am to 4:00pm**

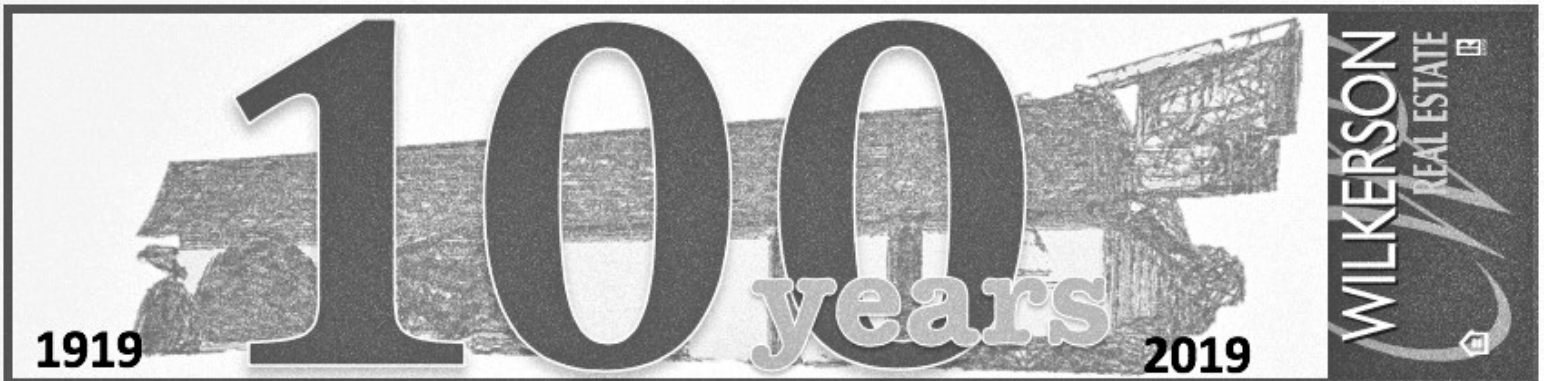

Contents of this newspaper is compiled from available original sources. The sources URL addresses are provided for readers' further reading, if so desired.

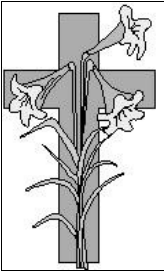

JEWELS FROM THE WORD

CRAPPIE DINNER I was hungry for fish. Money was tight, so I had tried begging my fisherman neighbor but he told me that he'd given away his last catch and his freezer was empty.

I remember praying a simple prayer, like "Jesus, I'd sure like to have some fish to eat." About 2 p.m. a kid from down the street rang the doorbell. This family had 3 or 4 little kids under 10 years old and they tormented me a lot, running in and out of my house all day long just like it was their own.

"Mom said to ask you if you want some fish." I was shocked. Was the Lord going to answer my prayer through them? Of course I said yes, and started to get the sink ready to clean them. Here came that kid again with a plate of fresh fried crappie hot off the fire. "Mom cooked these fish but us kids don't like 'em," and ran off to play.

That reminds me of another time that Jesus supplied the fish. It happened right after Jesus rose from the dead. Peter was discouraged and thinking about going back to his

old life. He told his friends, "I'm going fishing." They said, "We'll go with you." But they fished all night and caught nothing. When dawn broke, Jesus stood on the beach and called, "Boys, did you catch any fish? Do you have anything to eat with your bread?" They said, "No!"

He said to them, "Cast your net on the right side of the boat," and they caught so many they couldn't haul them all in. When Peter realized it was Jesus, he jumped off the boat and swam to shore. John 21:6. NKJV.

Jesus already had a fire going, and fish and bread ready to eat. "Come and eat, boys." The feast in heaven may just be crappie and fresh fried hush-puppies, cooked by Jesus Himself.

DATA MASTER: Heather Conn

Lavon Hightower Lewis To read more devotoials, go to:
<http://jewelsfromtheword.com/> Email me at llewis2138@sbcglobal.net

To share your story with us contact:
Zia Partovi at 918-244-0457 or 918-789-2862 or
email him at links@links.community-options.net



- Auto & Truck Loans
- Home Loans
- Business Loans
- Checking, Savings & CD's
- All of your Banking Needs!

THE BANK OF COMMERCE

789-2567

..... *Your Bank in Chelsea.....*



MEMBER FDIC



EQUAL HOUSING

LENDER